



IVERNA
2000

SUGARLIFT



SUGARLIFT Manual - Magnetic manhole cover lift system

Characteristics

- Device for lifting steel and cast iron drain or manhole covers up to 25 kg.
- Sugarlift along with a proper gesture with a straight back and bent knees will avoid damage to the back and greatly facilitate our work preventing injuries.
- Portable product with a weight of only 4 kg.
- Being a handy and lightweight tool, it can be stored in a small space.

Length	90 centimeters
Weight	4 Kg
Structure material	Galvanized steel
Magnet power	2 units of 140kg/each.
Loading limit	25 Kg*



- Double neodymium magnet of 280Kg joint force.
- Structure made of galvanized steel with high visibility tape to work in areas with traffic.
- The magnetic base has a lateral rotation system for much more efficient adhesion to the manhole cover, allowing an easier opening of the lid.



It is supplied with a fiberglass cover to prevent the actuation of the magnets and achieve a better conservation of these.

*Not recommended for use on heavier manhole covers, because the magnet is never in optimal conditions to work at 100% (surface that is not totally flat, irregular drawing of the lid, dirt or dust in the grip area...)

SUGARLIFT MANUAL

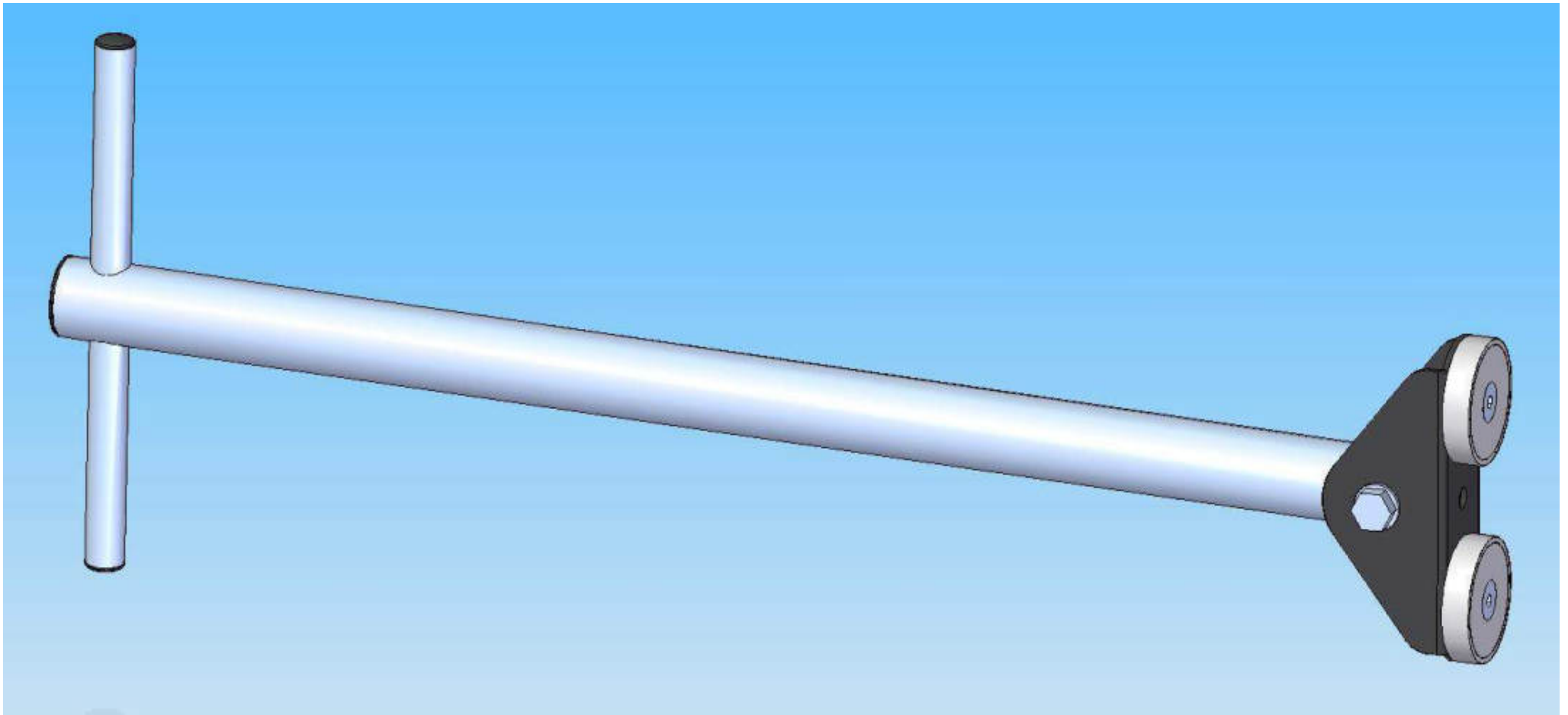

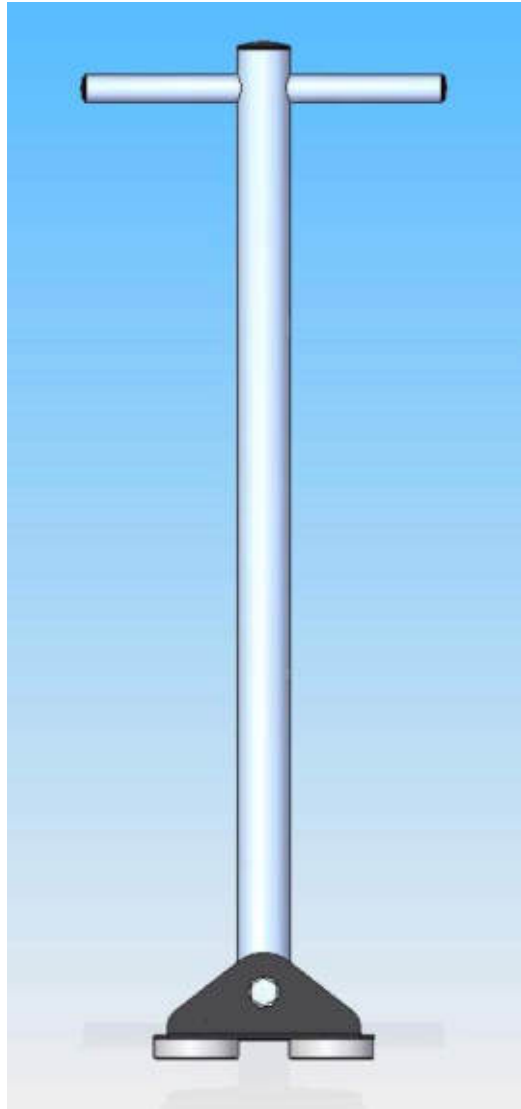

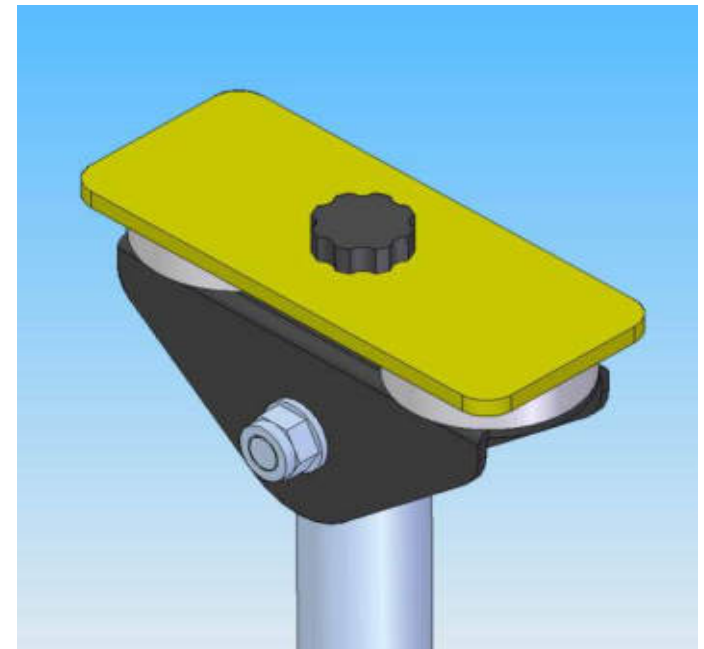
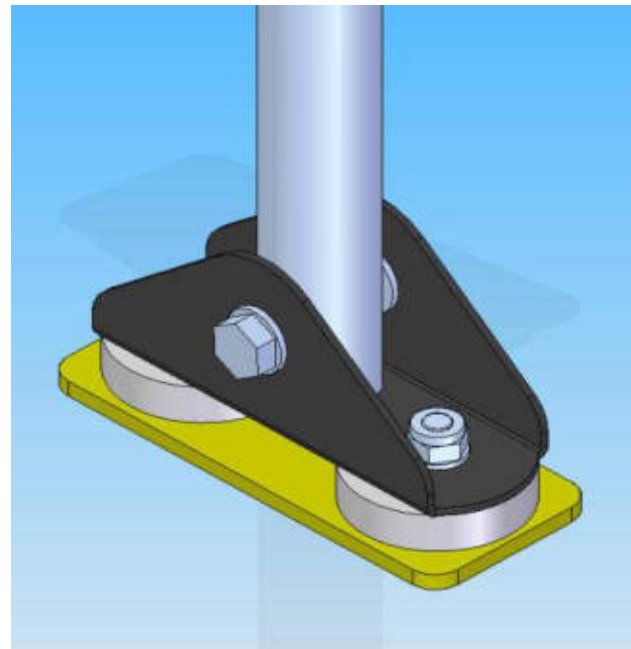
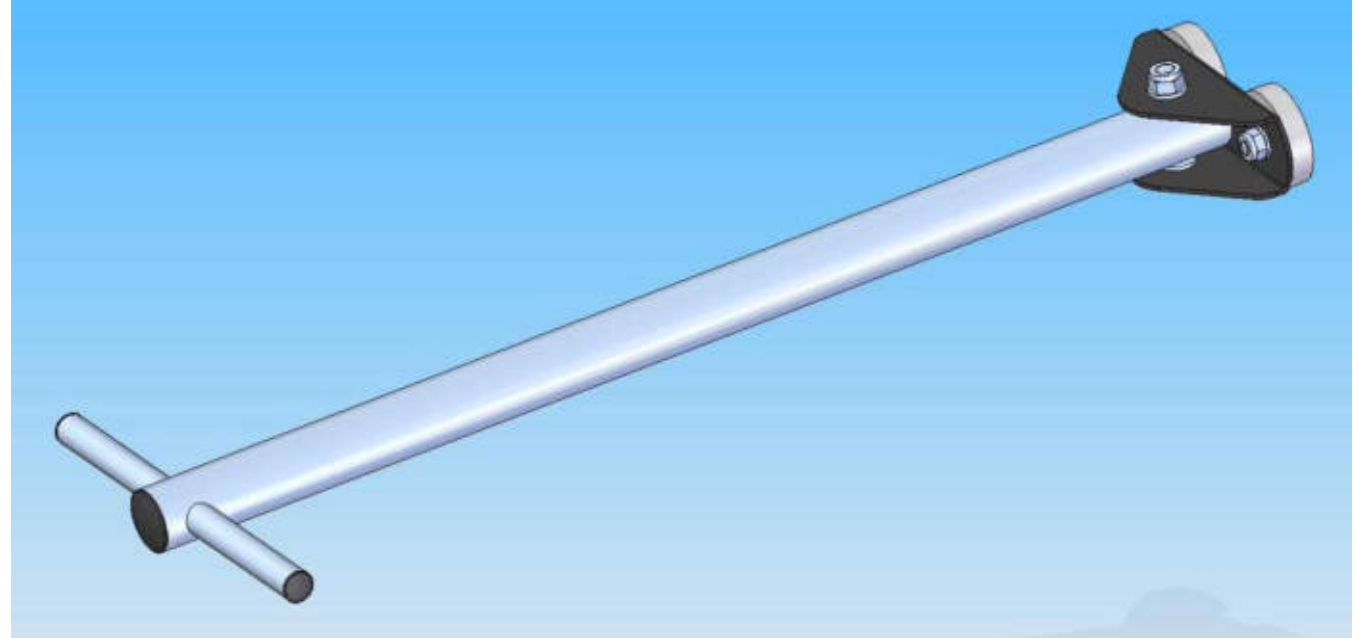
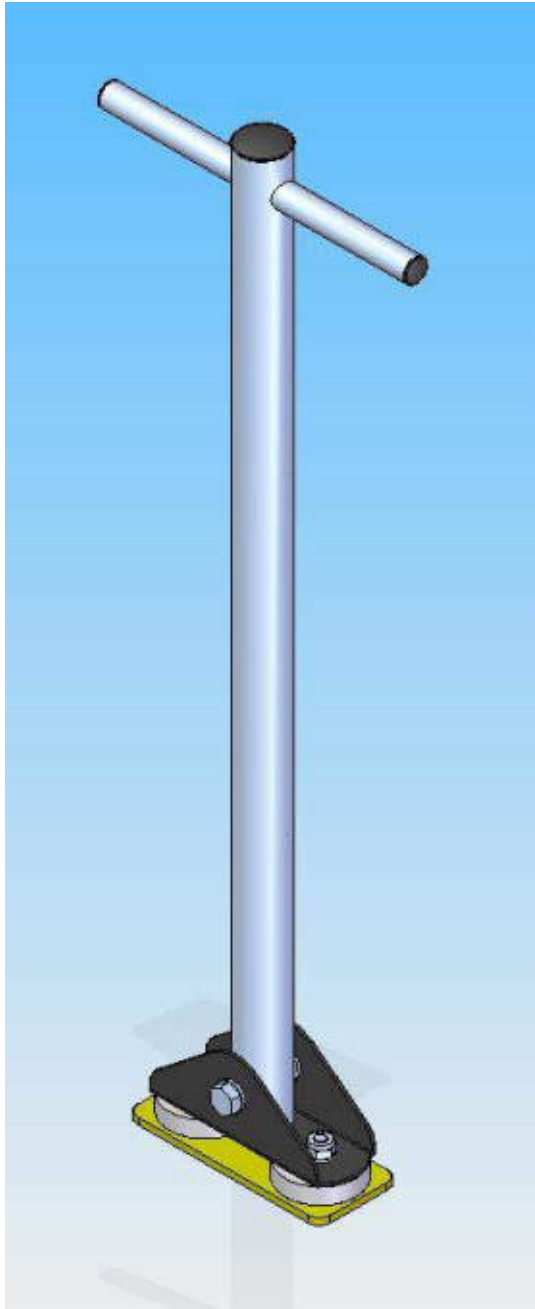

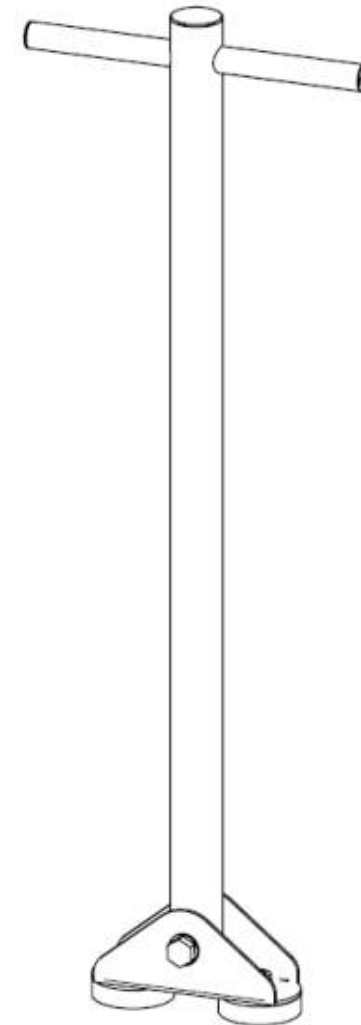
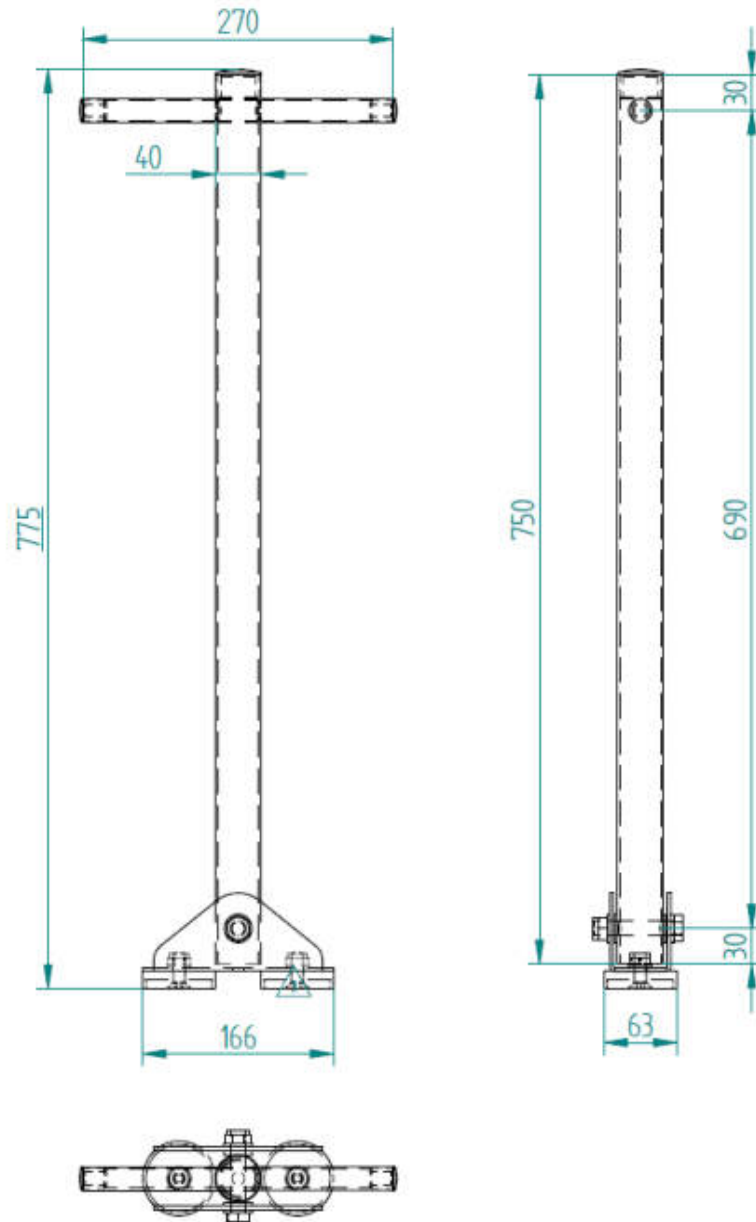

REVISION HISTORY			
REV	DESCRIPTION	DATE	APPROVED

<table border="1"> <tr> <th>NAME</th> <th>DATE</th> </tr> <tr> <td>DRAWN</td> <td>Ustavra 03/22/23</td> </tr> <tr> <td>CHECKED</td> <td> </td> </tr> <tr> <td>ENG APPR</td> <td> </td> </tr> <tr> <td>MGR APPR</td> <td> </td> </tr> </table>	NAME	DATE	DRAWN	Ustavra 03/22/23	CHECKED		ENG APPR		MGR APPR		<p>SOLID EDGE UGS - The PLM Company</p> <p>SUGARLIFT MANUAL</p> <p>UNLESS OTHERWISE SPECIFIED DIMENSIONS ARE IN MILLIMETERS ANGLES 45°</p> <p>2 PL. 30X33 3 PL. 40X33</p>	<table border="1"> <tr> <td>SIZE</td> <td>A2</td> <td>REV</td> <td> </td> </tr> <tr> <td>FILE NAME</td> <td colspan="3">IV_SUGARLIFT_MNL_CIT.dwg</td> </tr> <tr> <td>SCALE</td> <td> </td> <td>WEIGHT</td> <td> </td> </tr> <tr> <td colspan="4">SHEET 1 OF 1</td> </tr> </table>	SIZE	A2	REV		FILE NAME	IV_SUGARLIFT_MNL_CIT.dwg			SCALE		WEIGHT		SHEET 1 OF 1			
NAME	DATE																											
DRAWN	Ustavra 03/22/23																											
CHECKED																												
ENG APPR																												
MGR APPR																												
SIZE	A2	REV																										
FILE NAME	IV_SUGARLIFT_MNL_CIT.dwg																											
SCALE		WEIGHT																										
SHEET 1 OF 1																												